

SENSITIV T-TA

Boring and facing heads with manual and automatic feed



Index

SENSITIV T-TA

Boring and facing heads with manual and automatic feed

GENERAL FEATURES

p. 120

COMPONENTS AND ASSEMBLY

p. 121

SUPPLY

p. 122

ARBORS

p. 123

ACCESSORIES

p. 124-127

TECHNICAL DATA

p. 128

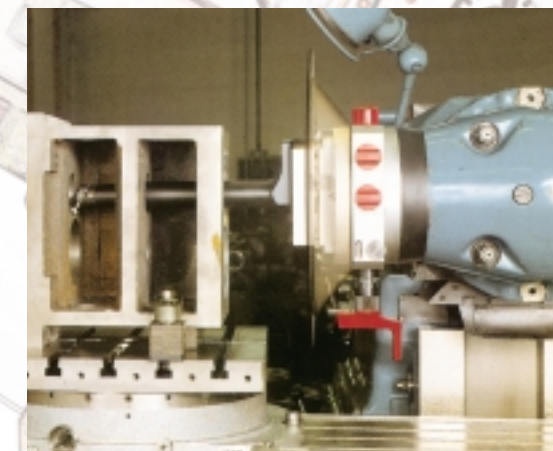

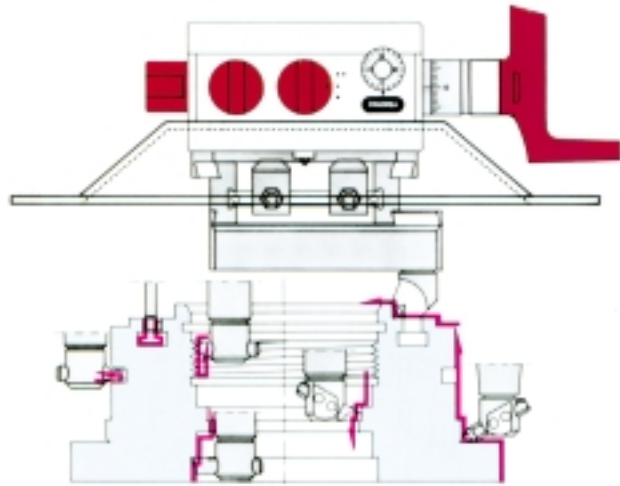

The line of T-TA boring and facing heads is provided with radial feed movement of the radial slide while the head rotates. The radial feed can be either manually operated by a crank or automatic. Via an interchangeable taper, these heads can be utilized on milling machines, boring machines, jig boring machine, radial drills and will allow to perform a wide range of machining operations such as facing, back-facing, boring, taper boring, grooving both on ID or OD. The T-TA line of heads includes 4 models: T 100 provided with manual radial feed only; TA 120, TA 170 and TA 220 provided with manual and automatic radial feed. A wide range of toolholders is available for these heads to allow the widest range of machining operations.

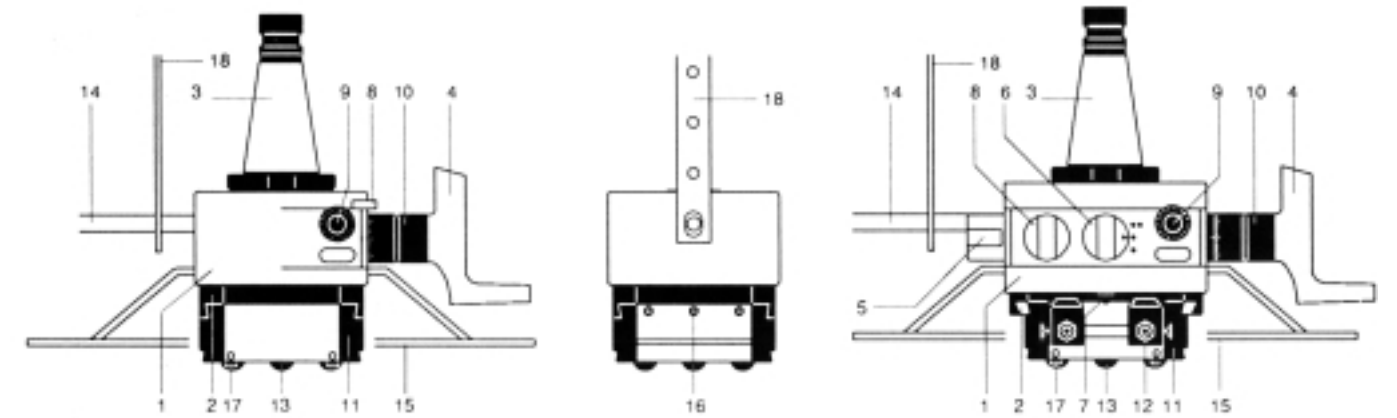
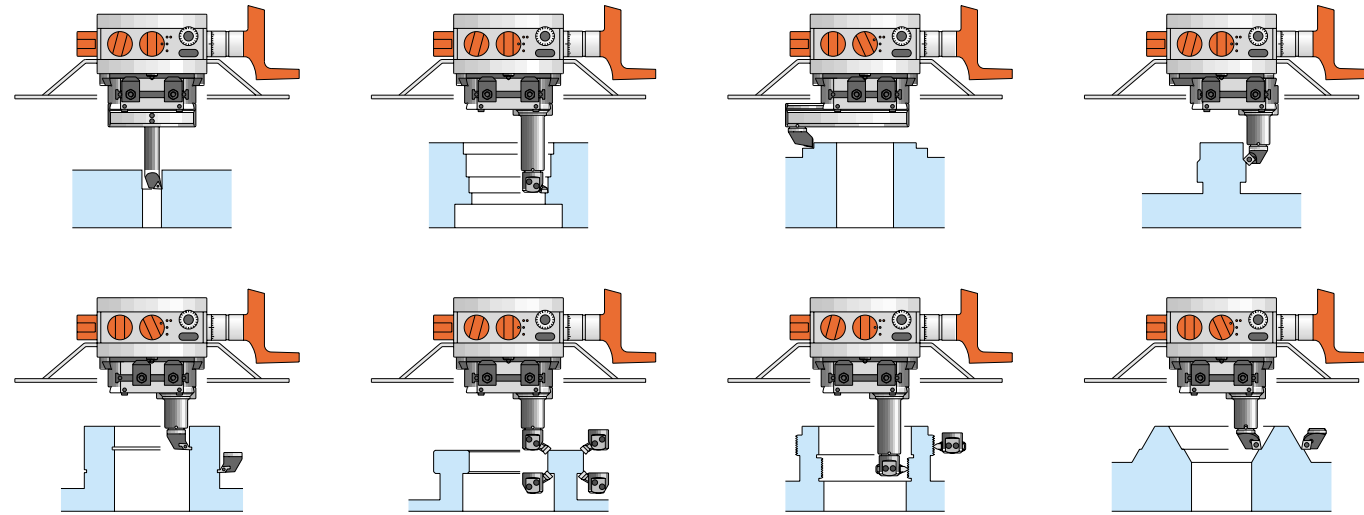

COMPONENTS

- | | | | | |
|-------------------------|------------------------------------|------------------------------|----------------------------|---------------------------|
| 1. Stationary body | 5. Quick return crank | 8. Crank lock | 12. Position stop | 16. Slide clamp screw |
| 2. Rotating body | 6. Automatic feed crank | 9. Micrometric vernier scale | 13. Toolholder clamp screw | 17. Toolholder check pins |
| 3. Interchangeable body | 7. Automatic feed disengage button | 10. Centesimal vernier scale | 14. Check rod | 18. Fork |
| 4. Feed crank | | 11. Tool slide | 15. Transparent guard | |

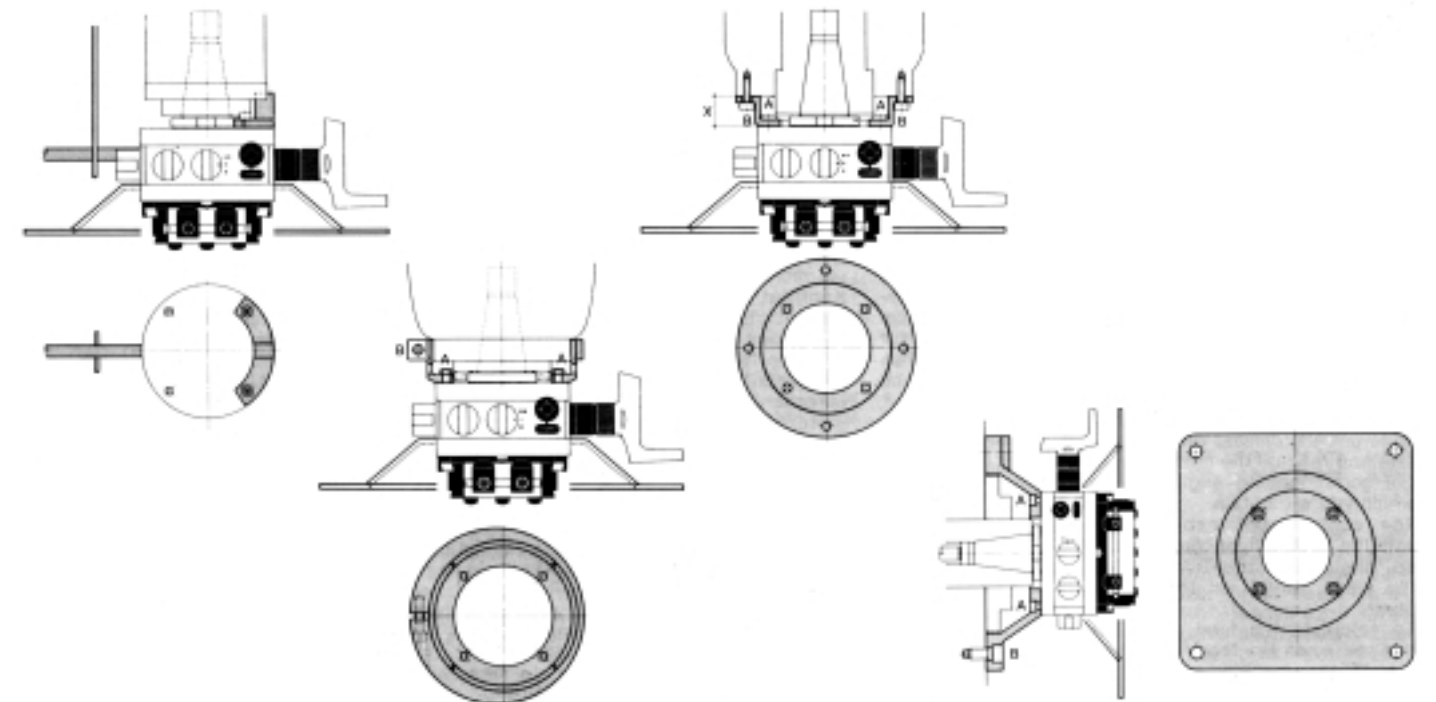

ASSEMBLY

The "SENSITIV" are mounted on the machine via the taper. The check rod 14, inserted in fork 18 and locked onto the machine head, prevents the fixed body from rotating. For severe, heavy tooling, it is advisable to apply a flange to block the "SENSITIV" onto the sleeve or the head of the machine tool. The type of flange to be used depends on the machine model and on whether or not there are threaded holes in the front of the spindle or machine head. The flange may be easily built by the customer or supplied by D'Andrea.

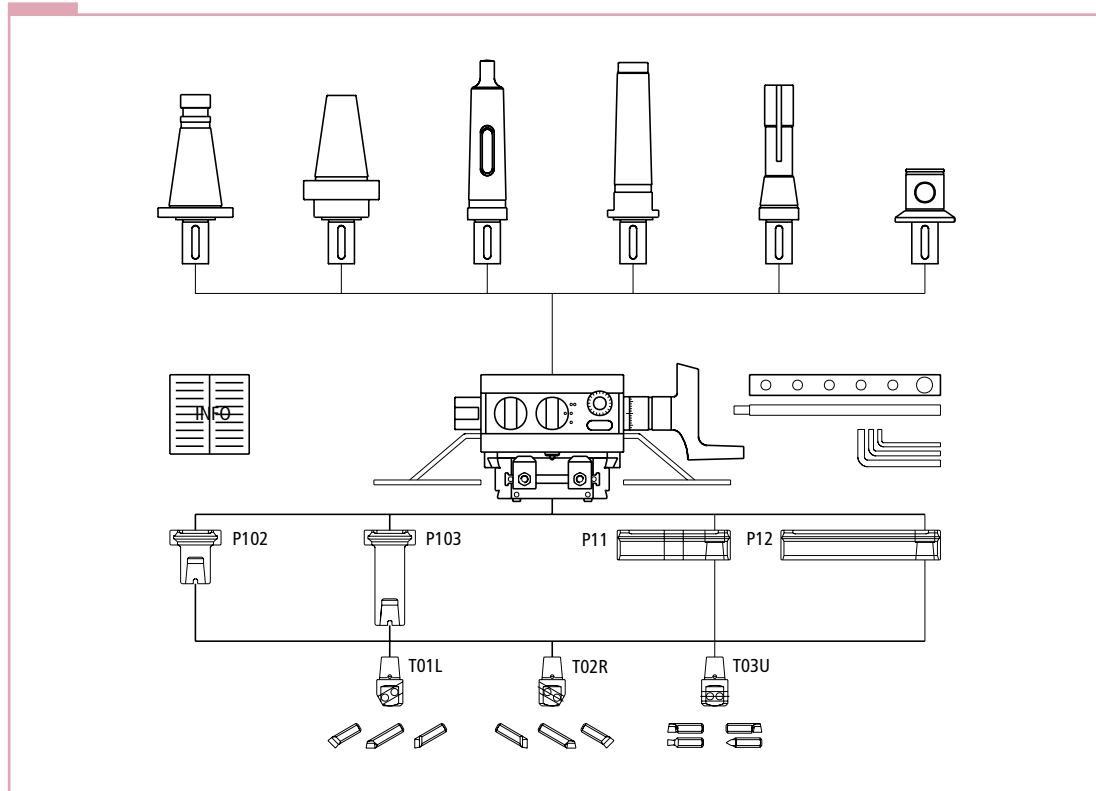

The standard K01 Kit includes the following in a case: 1 T or TA head; 1 transparent guard; 2 boring toolholders (P102, P103), 2 facing toolholders (P11, P12), 3 heads (T01, T02, T03), 10 carbide tools; 1 check rod; 1 set of wrenches; 1 instruction booklet; 1 warranty card. Other accessories are also available upon request. Fitting tapers are optional.

SAFETY
The T-TA are equipped with a transparent guard that ensures safe use. In addition, the toolholder slide is fitted with a safety device that prevents the tool holder from being released.

2

KIT K01

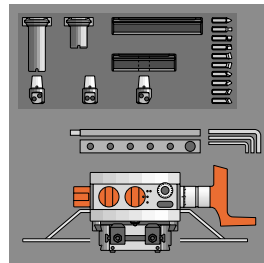

consisting of:

- 1 T../TA.. 1 T 01L
- 1 P 102 1 T 02R
- 1 P 103 1 T 03U
- 1 P 11 10 Tools M20
- 1 P 12

REF.	T100 COD.	TA 120 COD.	TA 170 COD.	TA 220 COD.
K01	50 01 100 21 001	50 02 120 21 001	50 02 170 21 001	50 02 220 21 001

KIT K03

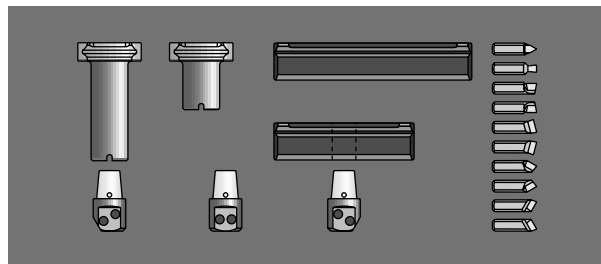

consisting of:

- 1 P 102 1 T 01L
- 1 P 103 1 T 02R
- 1 P 11 1 T 03U
- 1 P 12 10 Tools M20

REF.	T 100 - TA 120 COD.	TA 170 COD.	TA 220 COD.
K03	50 02 120 23 000	50 02 170 23 000	50 02 220 23 000



REF.		T 100 - TA 120 COD.	TA 170 COD.	TA 220 COD.
DIN 69871/CAT ISO 7388	ISO 40	41 1 22 01 040 35	41 1 32 01 040 35	-
	ISO 50	41 1 22 01 050 35	41 1 32 01 050 35	41 1 50 01 050 35
MAS-BT	ISO 40	41 1 22 01 040 36	41 1 32 01 040 36	-
	ISO 50	41 1 22 01 050 35	41 1 32 01 050 35	41 1 50 01 050 35

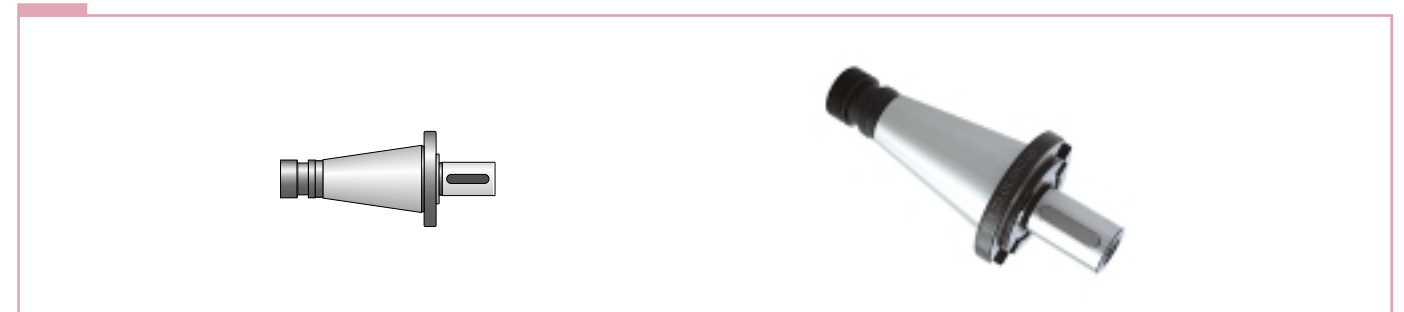

REF.		T 100 - TA 120 COD.	TA 170 COD.	TA 220 COD.
DIN 2080 "OTT"	ISO 40	41 1 22 01 040 00	41 1 32 01 040 00	-
	ISO 40 inch	41 1 22 01 040 04	41 1 32 01 040 04	-
	ISO 50	41 1 22 01 050 00	41 1 32 01 050 00	41 1 50 01 050 00
	ISO 50 inch	41 1 22 01 050 04	41 1 32 01 050 04	41 1 50 01 050 04

CHUCKING TOOL FOR MHD' ARBORS

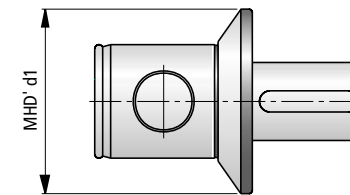

REF.	T100 - TA 120 COD.	MHD' d1
MHD' 50 T100 / TA120	41 1 22 00 050 00	50
REF.	TA 170 COD.	MHD' d1
MHD' 63 TA 170	41 1 32 00 063 00	63
REF.	TA 220 COD.	MHD' d1
MHD' 80 TA 220	41 1 50 00 080 00	80

123

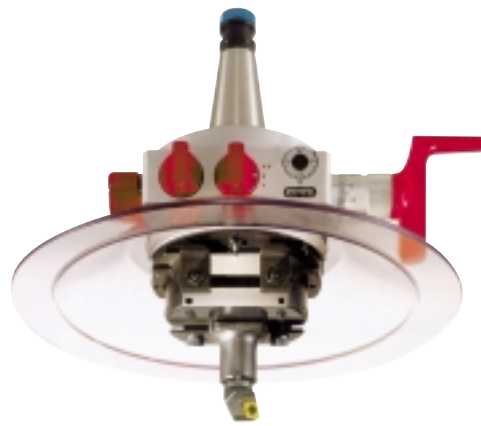

T and TA heads are designed for applying modular toolholders and interchangeable fitting tapers. All heads are made with dovetail guides on the slide for mounting the tool holders. This allows optimum positioning of the toolholders and ensures that they are very securely fastened in place. The toolholders have a tapered fitting for inserting the interchangeable heads available in right and left versions, screw-locking positive inserts and for round tools specifically made of carbide (M20).

BORING TOOLHOLDERS

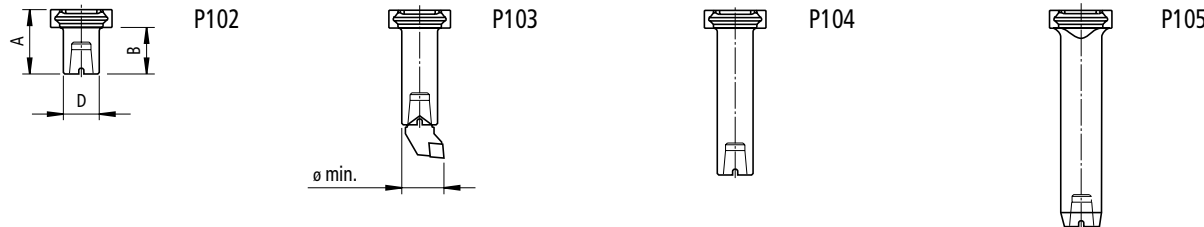

	REF.	COD.	A	B	D	Ø min.
T 100 - TA 120	P102	43 10 30 25 055 1	45	32,5	25	31
	P103	43 10 30 25 090 1	80	67,5		
	P104	43 10 30 25 125 1	115	102,5		
	P105	43 10 30 28 160 1	150	137,5		
TA 170	P102	43 10 40 32 080 1	67	51	32	40
	P103	43 10 40 32 125 1	112	96		
	P104	43 10 40 32 160 1	147	131		
	P105	43 10 40 32 200 1	187	171		
TA 220	P102	43 10 50 40 100 1	83.5	63,5	40	50
	P103	43 10 50 40 160 1	143.5	123.5		
	P104	43 10 50 40 200 1	183.5	163.5		
	P105	43 10 50 40 250 1	233.5	213.5		

FACING TOOLHOLDERS

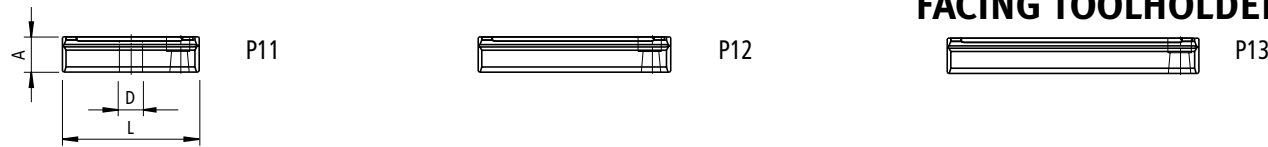

	REF.	COD.	L	A	Ø
T 100 - TA 120	P11	43 30 30 30 096 0	95	25	16
	P12	43 30 30 30 135 0	135		
	P13	43 30 30 30 175 0	175		
TA 170	P11	43 30 40 40 140 0	140	40	20
	P12	43 30 40 40 200 0	200		
	P13	43 30 40 40 260 0	260		
TA 220	P11	43 30 50 50 190 0	190	50	25
	P12	43 30 50 50 290 0	290		
	P13	43 30 50 50 390 0	390		

HEADS

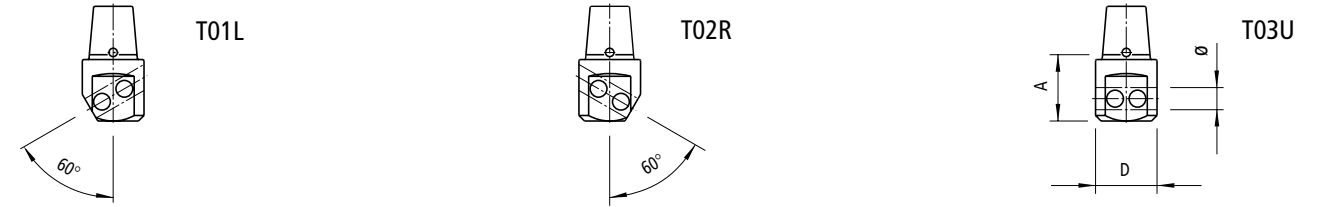

	REF.	COD.	D	A	Ø
T 100 - TA 120	T01 L	46 01 020 08 4 10	22	23.5	8
	T02 R	46 01 020 08 4 20			
	T03 U	46 01 020 08 7 30			
TA 170	T01 L	46 01 025 10 4 10	27	29.5	10
	T02 R	46 01 025 10 4 20			
	T03 U	46 01 025 10 7 30			
TA 220	T01 L	46 01 032 12 4 10	34	37	12
	T02 R	46 01 032 12 4 20			
	T03 U	46 01 032 12 7 30			

TOOLS

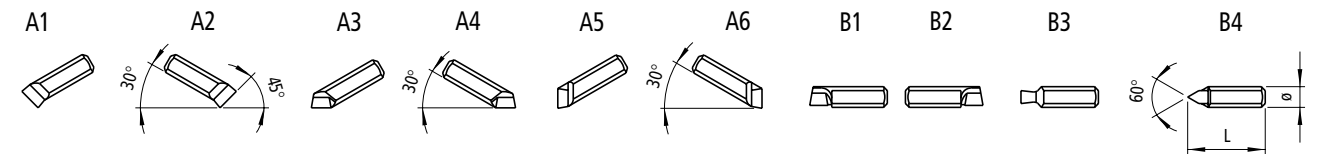

		T 100 TA 120		TA 170		TA 220	
REF.	COD.	Ø	L	REF.	COD.	Ø	L
A1 08 M20	47 201 02 08 001	8	30	A1 10 M20	47 201 02 10 001	10	45
A2 08 M20	47 201 02 08 002			A2 10 M20	47 201 02 10 002		
A3 08 M20	47 201 02 08 003			A3 10 M20	47 201 02 10 003		
A4 08 M20	47 201 02 08 004			A4 10 M20	47 201 02 10 004		
A5 08 M20	47 201 02 08 005			A5 10 M20	47 201 02 10 005		
A6 08 M20	47 201 02 08 006			A6 10 M20	47 201 02 10 006		
B1 08 M20	47 201 02 08 101	12	56	B1 10 M20	47 201 02 10 101	12	56
B2 08 M20	47 201 02 08 102			B2 10 M20	47 201 02 10 102		
B3 08 M20	47 201 02 08 103			B3 10 M20	47 201 02 10 103		
B4 08 M20	47 201 02 08 104			B4 10 M20	47 201 02 10 104		
A1 12 M20	47 201 02 12 001			A1 12 M20	47 201 02 12 001		
A2 12 M20	47 201 02 12 002			A2 12 M20	47 201 02 12 002		
A3 12 M20	47 201 02 12 003			A3 12 M20	47 201 02 12 003		
A4 12 M20	47 201 02 12 004			A4 12 M20	47 201 02 12 004		
A5 12 M20	47 201 02 12 005	A5 12 M20	47 201 02 12 005				
A6 12 M20	47 201 02 12 006	A6 12 M20	47 201 02 12 006				
B1 12 M20	47 201 02 12 101	B1 12 M20	47 201 02 12 101				
B2 12 M20	47 201 02 12 102	B2 12 M20	47 201 02 12 102				
B3 12 M20	47 201 02 12 103	B3 12 M20	47 201 02 12 103				
B4 12 M20	47 201 02 12 104	B4 12 M20	47 201 02 12 104				

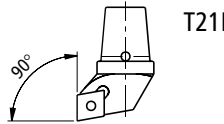

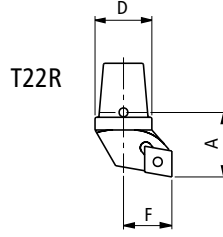

T21L



T22R

HEADS

	REF.	COD.	D	A	F			
T 100 - TA 120	T21 L	46 01 020 11 0 10	20	22.5	17	CCMT 09T3..	49 40 1 0004008	10 150 09 0150 0
	T22 R	46 01 020 11 0 20						
TA 170	T21 L	46 01 025 16 0 10	25	29	22	CCMT 09T3..	49 40 1 0004008	10 150 09 0150 0
	T22 R	46 01 025 16 0 20						
TA 220	T21 L	46 01 032 16 0 10	32	36.5	27	CCMT 1204..	49 40 1 0005009	10 150 09 0250 0
	T22 R	46 01 032 16 0 20						

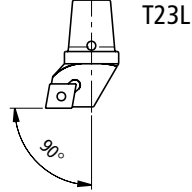

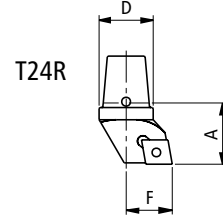

T23L



T24R

HEADS

	REF.	COD.	D	A	F			
T 100 - TA 120	T23 L	46 01 020 11 7 10	20	22.5	17	CCMT 09T3..	49 40 1 0004008	10 150 09 0150 0
	T24 R	46 01 020 11 7 20						
TA 170	T23 L	46 01 025 16 7 10	25	29	22	CCMT 09T3..	49 40 1 0004008	10 150 09 0150 0
	T24 R	46 01 025 16 7 20						
TA 220	T23 L	46 01 032 16 7 10	32	36.5	27	CCMT 1204..	49 40 1 0005009	10 150 09 0250 0
	T24 R	46 01 032 16 7 20						

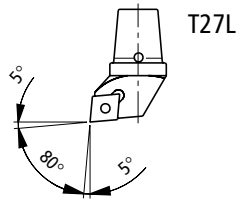

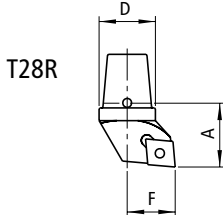

T27L



T28R

HEADS

	REF.	COD.	D	A	F			
T 100 - TA 120	T27 L	46 01 020 09 9 10	20	22.5	17	CCMT 09T3..	49 40 1 0004008	10 150 09 0150 0
	T28 R	46 01 020 09 9 20						
TA 170	T27 L	46 01 025 09 9 10	25	29	22	CCMT 09T3..	49 40 1 0004008	10 150 09 0150 0
	T28 R	46 01 025 09 9 20						
TA 220	T27 L	46 01 032 12 9 10	32	36.5	27	CCMT 1204..	49 40 1 0005009	10 150 09 0250 0
	T28 R	46 01 032 12 9 20						

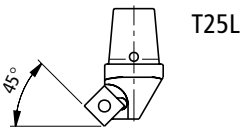

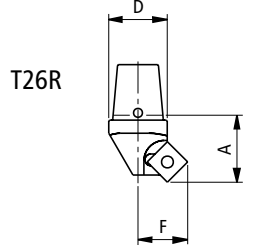

T25L



T26R

HEADS

	REF.	COD.	D	A	F			
T 100 - TA 120	T25 L	46 01 020 09 3 10	20	22.5	17	SCMT 09T3..	49 40 1 0004008	10 150 09 0150 0
	T26 R	46 01 020 09 3 20						
TA 170	T25 L	46 01 025 09 3 10	25	29	20	SCMT 09T3..	49 40 1 0004008	10 150 09 0150 0
	T26 R	46 01 025 09 3 20						
TA 220	T25 L	46 01 032 12 3 10	32	36.5	25	SCMT 1204..	49 40 1 0005009	10 150 09 0250 0
	T26 R	46 01 032 12 3 20						

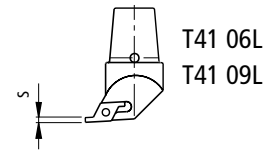

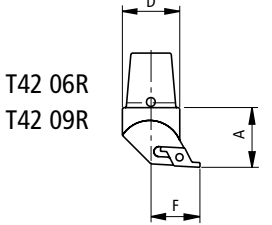

T41 06L
T41 09L



T42 06R
T42 09R

HEADS

	REF.	COD.	D	A	F			
T 100 - TA 120	T41.06 L	46 01 020 06 8 10	20	22.5	17	X61 0602..	49 20 1 0025050	10 150 09 0070 0
	T42.06 R	46 01 020 06 8 20						
TA 170	T41.06 L	46 01 025 06 8 10	25	29	22	X61 0602..	49 20 1 0025050	10 150 09 0070 0
	T42.06 R	46 01 025 06 8 20						
	T41.09 L	46 01 025 09 8 10						
	T42.09 R	46 01 025 09 8 20						
TA 220	T41.06 L	46 01 032 06 8 10	32	36.5	27	X61 0602..	49 20 1 0025050	10 150 09 0070 0
	T42.06 R	46 01 032 06 8 20						
	T41.09 L	46 01 032 09 8 10						
	T42.09 R	46 01 032 09 8 20						

On right heads (R) left inserts (L) are used and vice versa



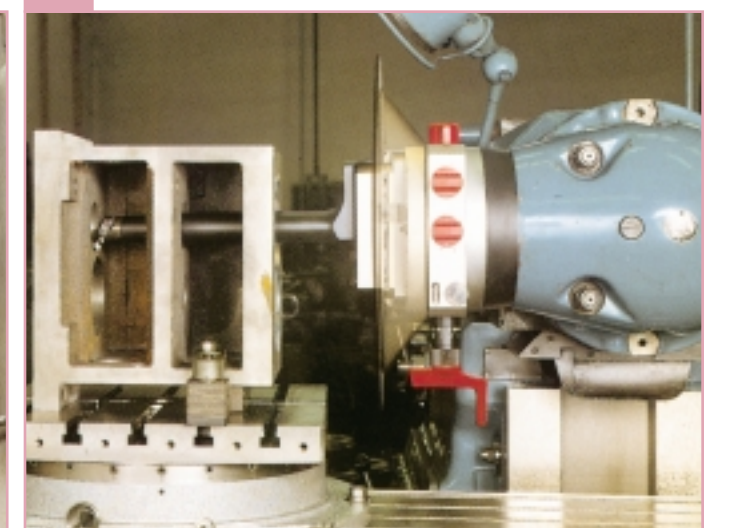
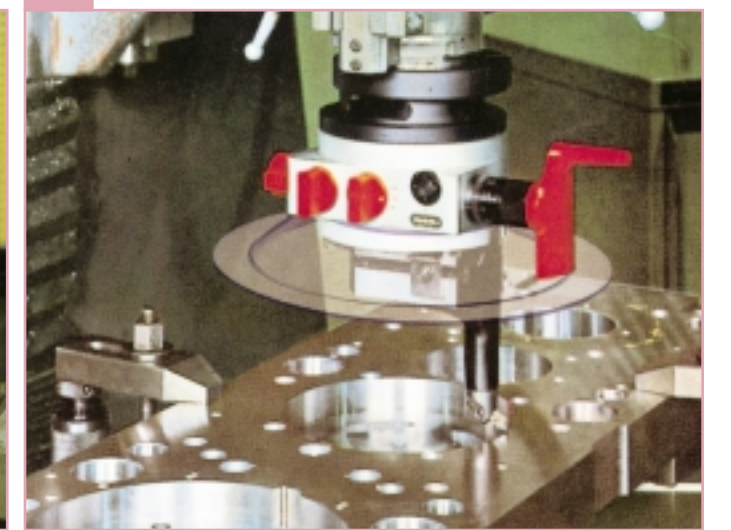
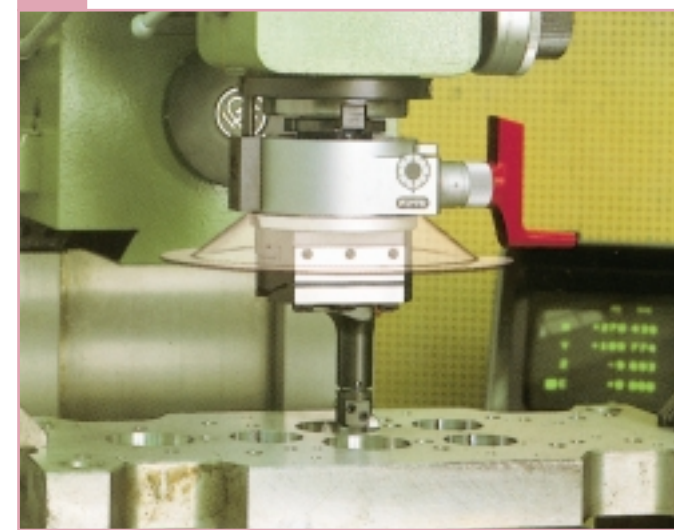
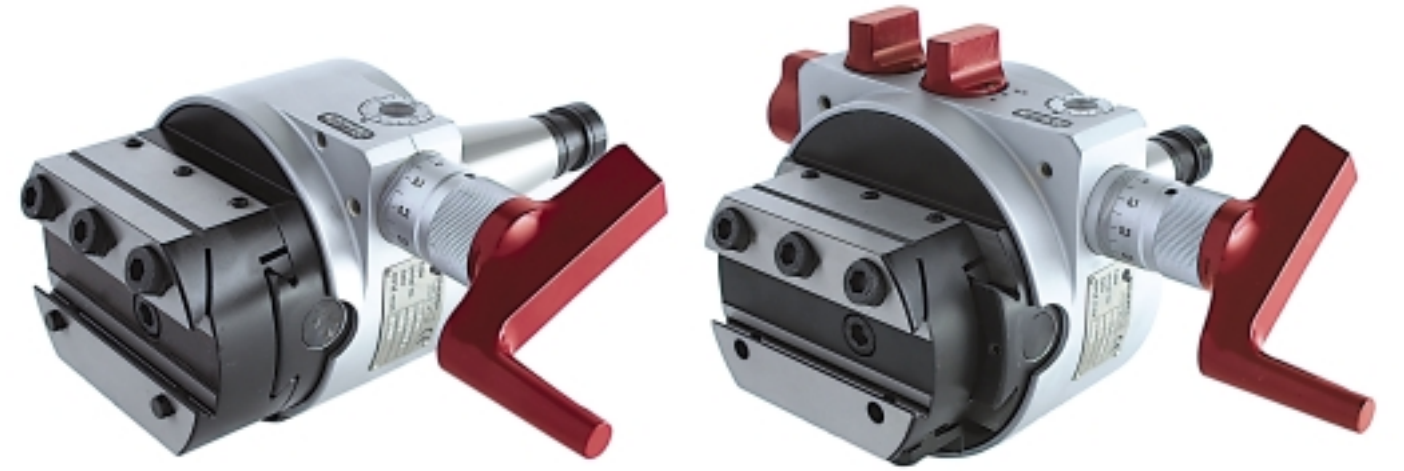
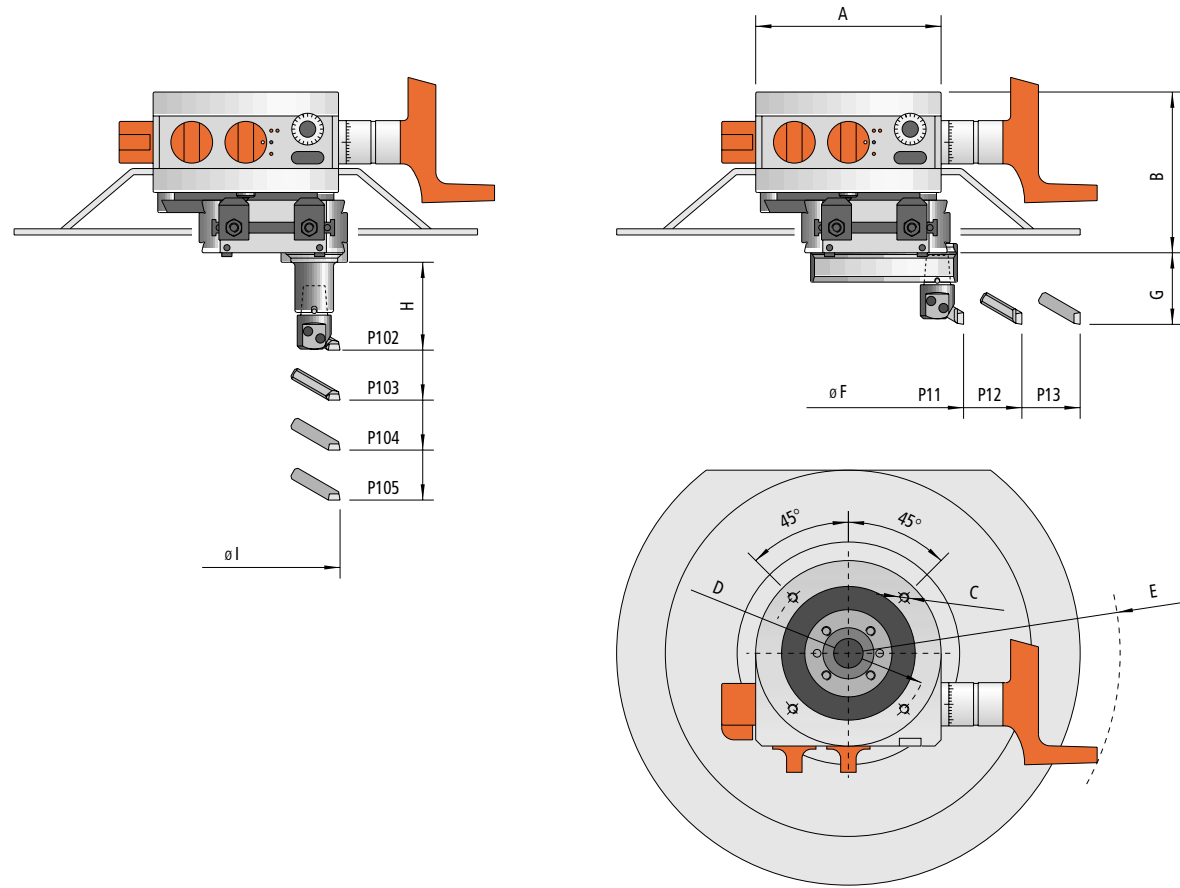

			T 100		TA 120		TA 170		TA 220	
A	mm	inch	102	4.01"	120	4.72"	170	6.69"	220	8.66"
B	mm	inch	100	3.93"	103	4.05"	128	5.03"	168	6.61"
C	mm	inch	M6		M6		M8		M12	
D	mm	inch	88	3.46"	102	4.01"	144	5.66"	190	7.48"
E	mm	inch	160	6.29"	178	7.00"	248	9.76"	283	11.14"
F max P 11 standard	mm	inch	140	5.51"	150	5.90"	220	8.66"	320	12.6"
P 12 standard	mm	inch	200	7.87"	210	8.26"	300	11.81"	420	16.53"
P 13	mm	inch	250	9.84"	300	11.81"	400	15.74"	500	19.68"
G	mm	inch	47	1.85"	47	1.85"	61	2.40"	77	3.03"
H P102 standard	mm	inch	55	2.16"	55	2.16"	80	3.14"	100	3.93"
P103 standard	mm	inch	90	3.54"	90	3.54"	125	4.92"	160	6.29"
P104	mm	inch	125	4.92"	125	4.92"	160	6.29"	200	7.87"
P105	mm	inch	160	6.29"	160	6.29"	200	7.87"	250	9.84"
I max.	mm	inch	115	4.52"	125	4.92"	190	7.48"	280	11.02"
Radial trasverse	mm	inch	30	1.18"	40	1.57"	60	2.36"	100	3.93"
• Feed	mm/°	inch/°	-	-	0.05	.002"	0.05	.002"	0.062	.0025"
• • Feed	mm/°	inch/°	-	-	0.15	.006"	0.15	.006"	0.186	.0073"
Rapid return	mm/°	inch/°	-	-	0.4	.015"	1	.039"	1.24	.048"
Max. speed	RPM	RPM	1500	1500	1000	1000	800	800	600	600
Net weight	kg	pound	4.6	10.12	6.5	14.3	19	41.8	36	79.2
Torque	Nm	lb ft.	400	296	400	296	800	592	1500	1110
Motor power	Kw	hp	2 ÷ 6	2.68 ÷ 8.04	2 ÷ 6	2.68 ÷ 8.04	3.5 ÷ 11	4.69 ÷ 14.74	7.5 ÷ 22	10.05 ÷ 29.48